

Characteristics

- Material**
- Sheet Steel (EN 10130 DC01)
    - Body : 1 mm
    - Glazed door : 1 mm
  - Galvanized Steel (EN 10346 DX51D+Z)
    - 19" profile : 1.5 mm
- Surface Finishing**
- RAL7035w powder coating
- Others**
- Optimum natural air circulation
  - Perforated top and bottom panel
  - Recessed wall mounting with cable entry from top and bottom
  - Glazed and perforated front door with double-bit cam lock
  - Removable perforated side panels
  - Depth adjustable 19" upright profiles



On Request

- Special sizes
- Special colour
- Pre-punching

Supply Includes

- Body
- Door
- 2 pcs 19" upright profile

Complementary Accessories

- Patch panel
- 19" equipment shelf
- Earthing cable

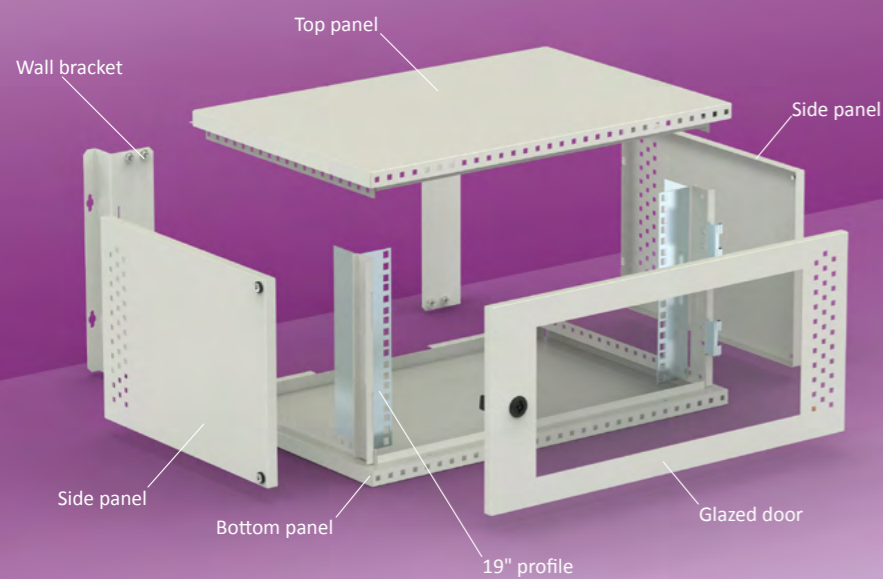

Height units *	Width			Reference	Lock	Hinge	Apparent Area		Gland Plate		Wall Mounting		Weight
	A	B	C				↔	↕	↔	↗	↔	↕	
	mm	mm	mm				mm	mm	mm	mm	mm	mm	
7 U	600	368	400	CR 0607U40	1	2	440	245	440	40	622	212	13.0
9 U		457	500	CR 0609U50	1	2	440	333	440	40	622	301	16.0
		600	600	CR 0609U60	1	2	440	333	440	40	622	301	18.3
12 U		590	500	CR 0612U50	1	2	440	467	440	40	622	434	18.5
			600	600	CR 0612U60	1	2	440	467	440	40	622	434

\* 1U = 44.45 mm

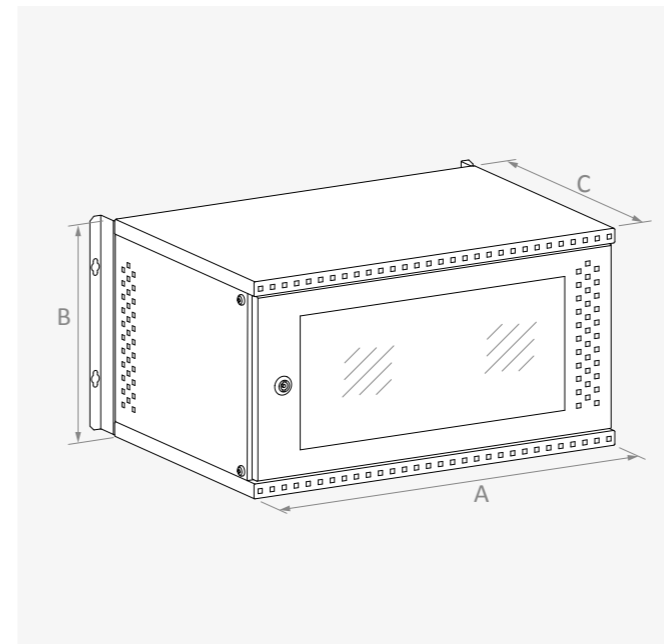

DOOR APPARENT AREA

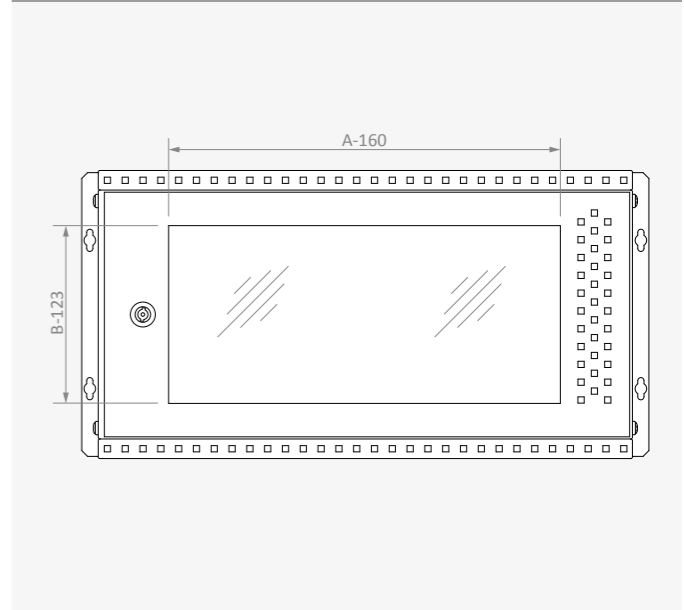

WALL MOUNTING & CABLE GLAND

