



Width A (mm)	Height B (mm)	Depth C (mm)	Enclosures Reference No	Weight (kg)	Type
80	160	60	JB 081606	0.6	1
100	100	60	JB 101006	0.5	1
120	120	60	JB 121206	0.6	1
150	150	60	JB 151506	0.9	2
160	160	80	JB 161608	1.1	2
200	200	80	JB 202008	1.5	2
300	200	100	JB 302010	2.2	2
	300	100	JB 303010	2.8	2
400	200	100	JB 402010	2.8	2
	300	100	JB 403010	3.7	2
	400	100	JB 404010	4.6	2

Characteristics :

- Sheet steel enclosure : 1.2 mm
- top cover : 1.2 mm
- One piece neoprene sealing gasket.
- IP 55 protection (TS 3033, EN 60529).
- Powder coating (RAL 7032w).

On Request :

- Special colour.
- Special sizes.
- Pre-punching.

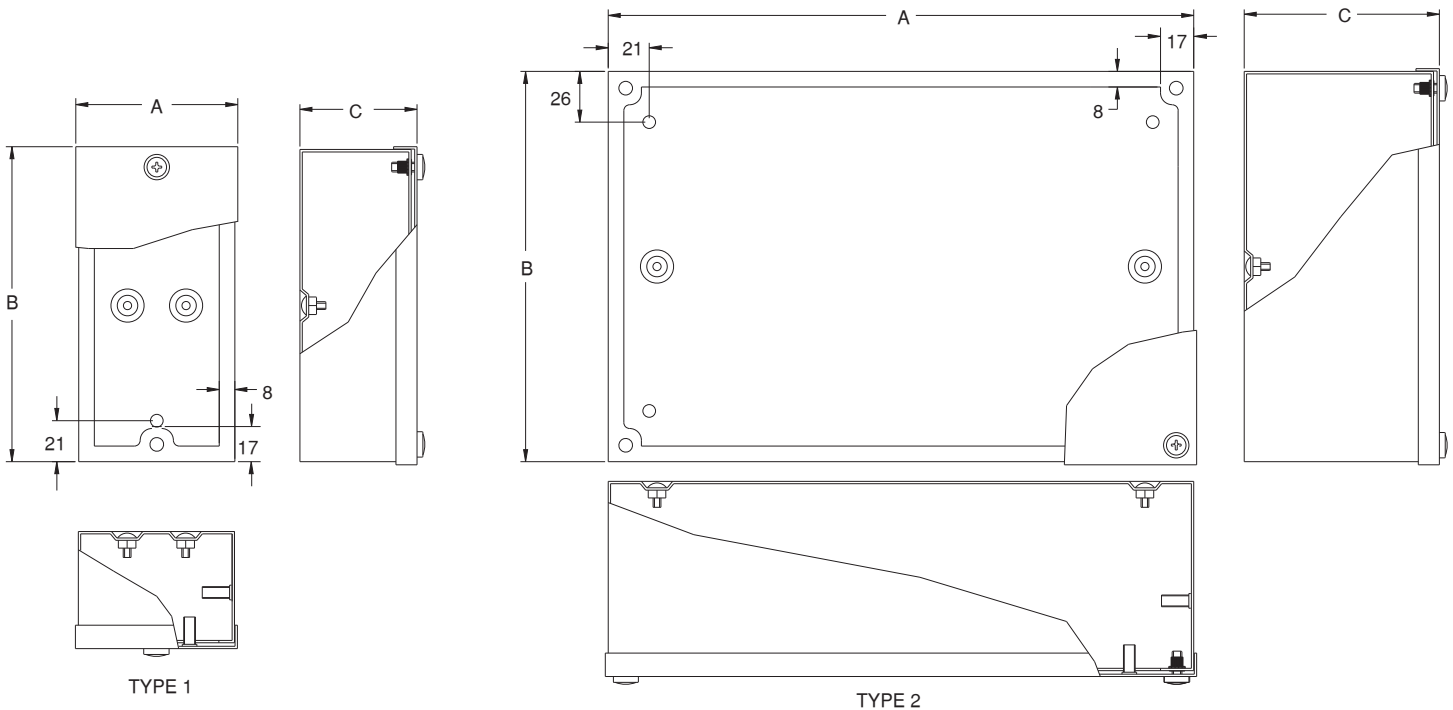

Wall Brackets

Fastens to rear holes in the enclosures.

Reference No
AXKL010

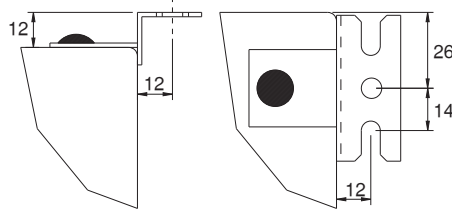

Material : Sheet steel, zinc plated, colour passivated (Cr⁺⁶ free).

Support Rails

Support Rails (DIN 46277 - EN 50022)

Support Rails Reference No	Dimensions (mm)		
	Width	Height	Length
MR KL500604	35	7.5	2000
MR KL500603*	35	7.5	2000
MR KL500609	35	15	2000

* Support rail without holes.

Material : Sheet steel, zinc plated, colour passivated (Cr⁺⁶ free).

